



AMBIKA ENGINEERING WORKS

19, Gr.Floor,Shanta Industrial Premises Co-op Society Ltd, I.BPatel Road, Goregaon (East) Mumbai - 400063

Tel : 022-26858793 • Cell : 09821271748 • Telefax : 022-26852558

JACKETED ANGULAR FLUSH BOTTOM VALVE

Salient Features and Specialities:

- Specially Designed for 300°C fluid (Hot Oil / Steam / Hot water / Cold Water)
- Positive shut off
- Longer life
- Quick in action
- No lubrication
- Visual on / off indication
- Compact design
- Corrosion resistant
- Low pressure drop

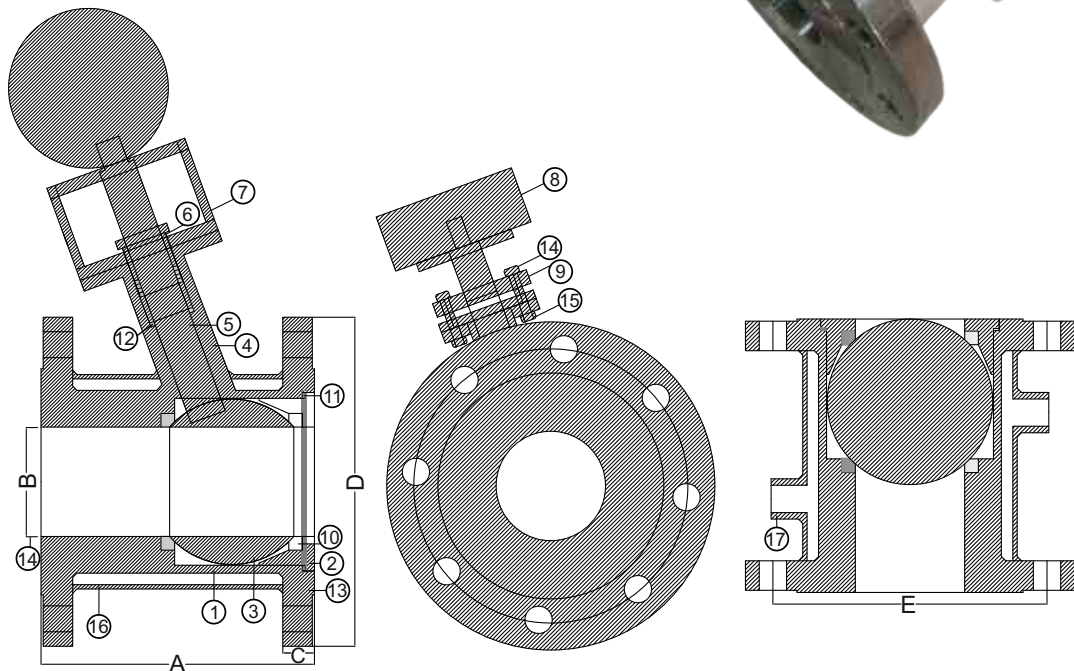

SR.NO.	NAME OFPART	MATERIAL	SR.NO.	NAME OFPART	MATERIAL	SR.NO.	NAME OFPART	MATERIAL
1	BODY	A.I.S.I.304/316	8	ACTUATOR		14	3/8BSWHEXBOLT	A.I.S.I.304
2	ADAPTOR	A.I.S.I.304/316	9	GL.RINGPATA	A.I.S.I.304	15	3/8BSWHEXNUT	A.I.S.I.304
3	BALL	C.F.8./C.F.8M.	10	SEAL	P.T.F.E.	16	JACKETPIPE	A.I.S.I.304
4	BONNET	A.I.S.I.304/316	11	BODYSEAL	P.T.F.E.	17	1/2" BSP COUPLINE	A.I.S.I.304
5	SPINDLE	A.I.S.I.304/316	12	GLANDSEAL	P.T.F.E.			
6	GLANDRING	A.I.S.I.304	13	4"A.S.A.150 FLANGE	A.I.S.I.304/316			
7	ACT.MOUNT.BREAKET	S.S./M.S.						

SIZE.	A.	B.	C.	D.	E.	AMBIKA ENGINEERING WORKS.			
4"X3"(N.B.)	190	76	22	2280(4"A.S.A.150)	190,5MM. P.C.D.19MM,HOLE-8NOS	FLUSHBOTTOM ANGULAR BALLVALVE JACKETED ACTUATOR OPERATED S.S.304/S.316			
							DRN C.J.MEWADA 05/12/2013	SKN C.J.MEWADA 05/12/2013	DATE 05/12/2013
						IND.PR.CO.SOCIETY.LTD, I.B.PATEL ROAD, GOREGAON (EAST), MUMBAI - 400063	CHKD. C.J.MEWADA N.T.S.	SCALE N.T.S.	DRG.NO. AEW/FL.B.B.V.ANG.ACT./118
						TELE. NO.-26858793 FAX. - 26852558	DRG.NO. AEW/FL.B.B.V.ANG.ACT./118		
						EMAIL:- valves@ambikavalves.com	WEB:- ambikavalves.com		
						CLINT:-			